

phibo^φ

TSH[®]



Biomaterials

Implant
Systems

CAD-CAM

Digital
Solutions

Services

IMPORTANT BEFORE USING Phibo®

In its innovative and patented design, the Phibo® implant system incorporates advanced technological features developed only for professionals who understand technology as an advantage, and design as a benefit.

Phibo® complies with all the demands and requirements of European Directive 93/42/EEC regarding the manufacture and distribution of medical-sanitary products. The products of the Phibo® implant system have CE marking, evaluated by NB 0123. The Quality System of Phibo Dental Solutions, S.L. complies with the strictest international quality norms, and is certified according to ISO 9001 and ISO 13485 by TÜV SÜD Product Service. In addition, Phibo Dental Solutions, S.L. has authorization from the FDA (Food and Drug Administration) to market its products in the United States, and consequently complies with the principles of GMP (Good Manufacturing Practice), as established by the strict requirements of norm 21 CFR 820 in that country, guaranteeing perfect product quality, and assuming as its sole objective a constant increase in client satisfaction.

The use of the other components or products not original of Phibo®, and which come into contact with the originals of the implant system according to the original design specifications, may cause serious patient health problems, since they have not been contemplated for use with those elements referenced in the documentation supplied by the manufacturer.

Any use of non-original components or instruments in this catalogue, that come into contact with the referred original components, will automatically cancel any type of warranty covering the Phibo® products.

The use and application of the Phibo® dental implant system are beyond the control of the manufacturer, and the user is responsible for any damage that may result from the use of the product. Phibo Dental Solutions, S.L. declines all responsibility for damage derived from its incorrect manipulation or use.

The documentation of the Phibo® implant system is periodically updated according to the state of scientific and technological knowledge. Users of the Phibo® system should request product information on a regular basis and take part in the regularly established training courses on the product and technique. The use and placement of Phibo® implants in inappropriate sectors, and the use of surgical instruments or prosthetic components not contemplated in this catalogue may cause serious patient health problems as well as total loss of the product warranty. The Phibo® implant system has been designed for single (unit) or multiple dental restorations according to the traditional clinical processes reflected in this documentation. Excluded from the warranty are cases involving insufficient bone for implant placement, clinical risk cases such as sinus lift procedures, fillings, advanced surgical techniques, cases of severe or non-apt disparallelism between implants, and other cases.

The Phibo® implant system is internationally distributed in various countries with different technical and healthcare regulations and laws; accordingly, there may be differences from one country to another in terms of the contents of the procedure. Consult the exclusive Phibo® distributor in your country and request the documentation relating to the products and their availability.

Phibo Dental Solutions, S.L. reserves the right to modify and develop the products reflected in this catalogue, without prior warning.

All rights reserved. Printing or processing the contents of this publication in any format requires prior written permission from Phibo®.

Phibo® Implants, Phibo® CAD-CAM, Tissue Care®, TSA® Advance, TSA®, TSH®, BNT®, Avantblast®, ProUnic®, ProUnic Plus®, Duplit®, Softissue, International Phibo Group®, Phibo® Prostodontics, Phibo® Scientific, are commercial and/or registered trademarks of Phibo Dental Solutions, S.L. Phibo® implants are protected by international patents. Other products and accessories are protected by patents or are patent pending.

The illustrations in this document are not made to scale.



TSH®

CONTENTS:

Design of the implant: macrodesign / microdesign	Page 04-05
A standardised, versatile and easy prosthetic connection	Page 06-07
A solution for each restoration	Page 08-09
Science and technology to obtain predictable results	Page 10-11
General characteristics	Page 12-13
Restoration	Page 14-15
Cemented, screwed restorations and overdentures	Page 16-17
Impression coping	Page 17
Planning instrumentation, surgical tray	Page 18
Surgical instruments	Page 19-22

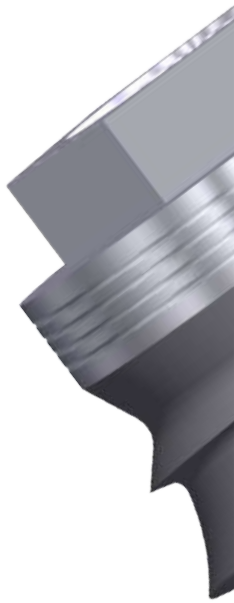

Design of the implant: Macrodesign / microdesign

Self-tapping profile

The body of the TSH® implant is self-tapping, and the outer tap design offers the following main advantages:

- **Minimally invasive characteristics.**
- **Directional tapping, to facilitate implant insertion and shorten the surgical times.**
- **Reduction of the increase in bone temperature during implant insertion.**
- **Biomechanical stimulation of the bone tissue.**
- **Maximum implant stability upon insertion.**

Avantblast Surface® (Patented)

Avantblast® is the surface of the Phibo® implant system. Continuing in the line of research on implant surface treatment based on chemical action, **Avantblast® offers advances and optimisation of biological response**, improving upon the results obtained with acid-etched surfaces and posterior passivating. Avantblast® combines key factors to facilitate biological response: **implant surface increase through optimised roughness and increased thickness of the titanium dioxide layer.**

The Avantblast® surface is manufactured in a controlled manner under dual chemical action, offering exclusive properties thanks to its notorious porosity. The resulting morphology, very similar to that of cancellous bone, **optimises the osteointegration process, implant anchoring to bone, and clinical success.** The exclusive morphology of the Avantblast® surface increases the effective surface of the implant while multiplying the thickness of the TiO₂ surface layer. All these factors afford **improved implant - bone binding, with increased retention force, lower release of metal ions into the environment, and greatly improved humectability.**

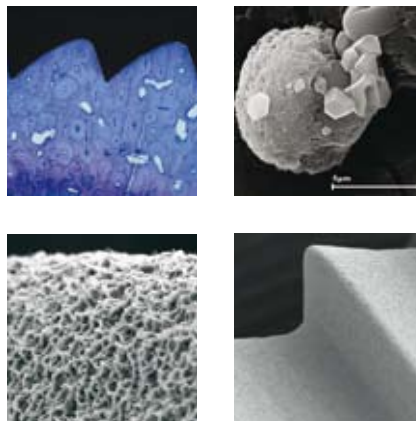

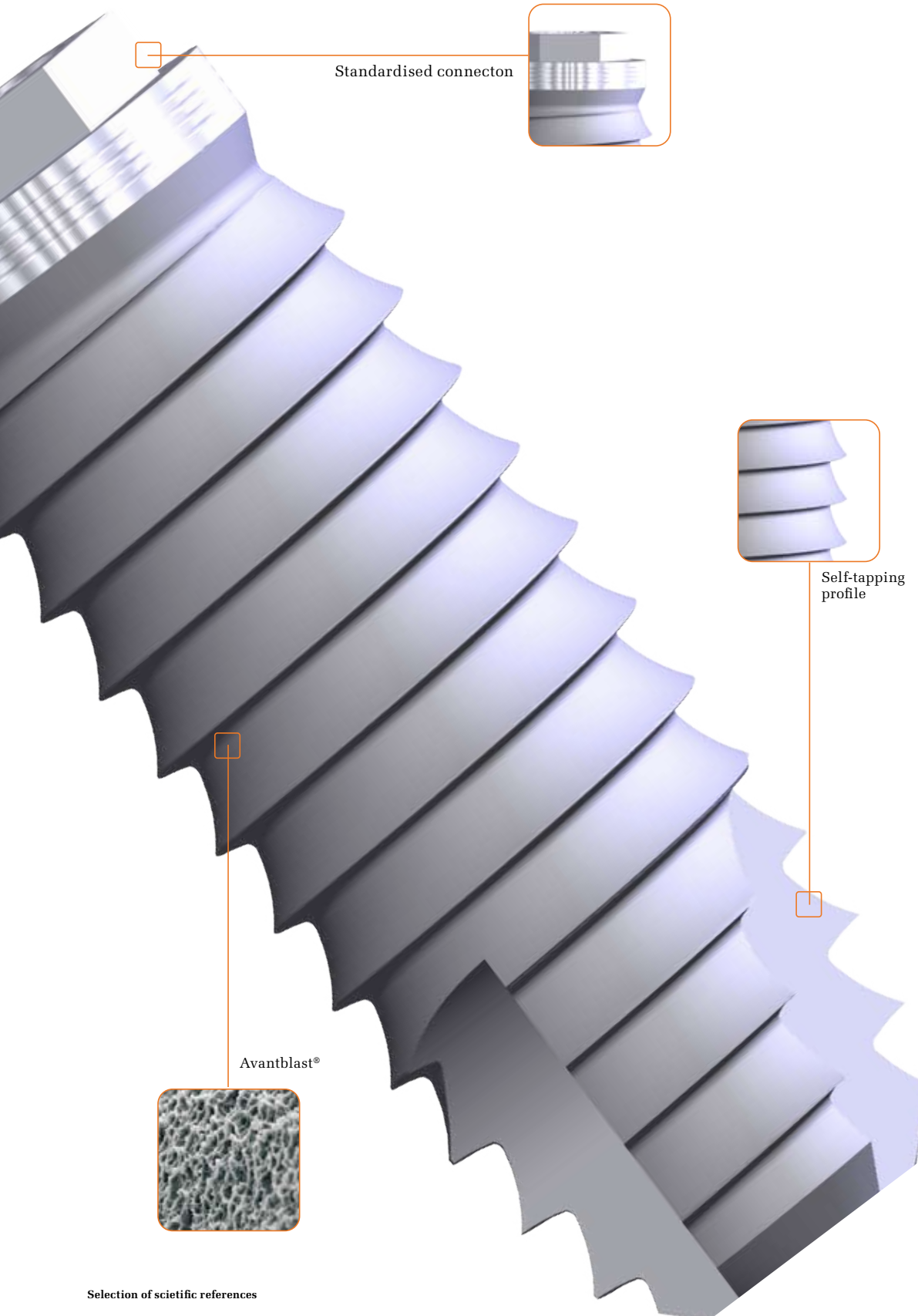

Standardised connecton

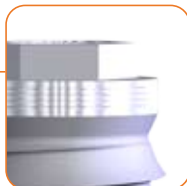

Self-tapping profile



Avantblast®

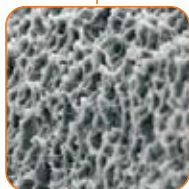

Selection of scietific references

Surface:

Clinical and Radiographic Behaviour of 290 dental implants with a surface treated with hydrofluoric acid and passivated with hydrofluoric and nitric acid: early loading results after 2 years.

Med Oral Patol Oral Cir Bucal 2006; 11:E281-5.

José María Martínez-González, Cristina Barona Dorado, Jorge Cano Sánchez, María Flórez Rodríguez, Miriam Cantero Álvarez.

Conclusions: The implant survival rate is 98.56%. Results after the prosthetic loading of 279 implants (survival rate 98.56%) attest that early loading may a must be applied, after a rigorous planning and case selection.

Physico-chemical characterization of the surface of 9 dental implants with 3 different surface treatments.

Med Oral Patol Oral Cir Bucal 2005; 10:58-65.

Daniel Rodríguez Rius, F. Javier García Sabán.

Conclusions: Avantblast treatment as a consequence and increased osseointegration and bone formation in contact with the surface of the implants when compared with other surfaces.

Osteointegration:

Early Loading of 642 Phibo Implants: 1-Year Follow-Up.

Journal of Oral and Maxillofacial Surgery 2007; 65 (11),

2317-2320.

Miguel Penarrocha PhD, DDS , Celia Carrillo DDS, Araceli

Boronat DDS and Eva Martí DDS, PhD.

Conclusions: The implant survival rate is 98.13%.

Primary stability:

Resonance frequency analysis after the placement of 133

dental implants.

Med Oral Patol Oral Cir Bucal 2006 May 1; 11(3):E272-6.

Boronat,A., Peñarrocha,M., Martinez-Cortissoz,O., and Minguez-Martinez,I.

Conclusions: The stability quotient of the implants on the day of surgery was 62.1, with an insertion force of 35.7 N.

For further information www.phibo.com

A standardised, versatile and easy prosthetic connection

TSH® Implants

The objective of the TSH® implants is to restore chewing, aesthetic and speech functions, replacing the missing teeth in the maxilla or mandible with dental implants placed in the remaining bone, and restoring the various functions by means of personalised prostheses.

Design of the implant

The Phibo® implant system has been designed to simplify and reduce the clinical processes and restoration times, yielding improved aesthetic results and patient comfort from the start, with the aim of ensuring tissue care and maintenance. This concept, together with standardisation of the TSH® implant connection, not only offers patient benefits from the start but also ensures increased dental clinical performance by reducing processes, times and components, as well as excellent short-, middle- and long-term clinical results.

Standardised connection

The TSH® implant has several shoulder diameters with external hexagons that afford the anti-rotation characteristic of the prosthetic elements fixed to the implant via locking of the final screw of the prosthesis. The platforms and heights of the hexagon for each series are the following:

Series 2

Platform diameter 3.3 mm, hexagon height 1.0 mm.

Series 3

Platform diameter 4.0 mm, hexagon height 0.7 mm.

Series 4

Platform diameter 4.0 mm, hexagon height 0.7 mm.

Series 5

Platform diameter 5.0 mm, hexagon height 1.0 mm.

Soft tissue care

The standard connecting abutments facilitate force distribution along the long axis of the implant, stimulating soft tissue adhesion to the crown portion of the implant and reducing stress at the implant-abutment connecting interface.

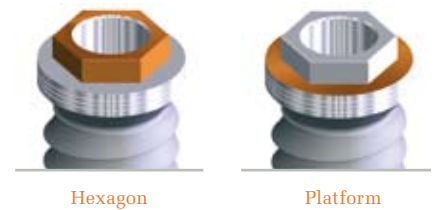

Hexagon

Platform



A solution for each restoration

This new business unit responds to the Phibo® strategic plan. This plan aims to offer top level dental solutions in the field of implant systems, biomaterials and CAD-CAM, in order to satisfy the demand and present and future needs of clinics, prosthetic laboratories and patients.

Phibo® CAD-CAM maintains the strong R&D dedication of the company, with the investment of important resources in this area. This synergy in the field of knowledge of implantology and prosthetic solutions based on CAD-CAM technology allows us to offer a broad catalogue of innovative and high-quality products, as well as a high added value technical support service.

Phibo® CAD-CAM aims to facilitate access to CAD-CAM technology on the part of prosthetic laboratories, based on a robust technological package and personalised training courses programmed by experts in the field.

Personalised crowns

Phibo® CAD-CAM, based on CAD-CAM technology, offers the possibility of producing personalised prostheses, ensuring highly aesthetic and precise results in an easy and safe manner, and improving clinical and laboratory processes.

Phibo® CAD-CAM offers reliable and precise products based on scientific - technical arguments that contribute to the best solutions in a competitive and differentiated manner, and over the long term. With a strong commitment to research and development, at the service of specialists in dental prostheses.

Phibo® CAD-CAM offers the latest advances in CAD-CAM technology. With a novel Technological Centre exclusively dedicated to the production of personalised prostheses, and with a robust quality system and total reliability in our products.

Phibo® CAD-CAM offers the broadest range of materials made from Zirconium, Titanium, Cobalt Chrome and Plastics.

Improved aesthetics

The incorporation of aesthetic materials such as zirconium facilitates the manufacture of personalised prostheses with more predictable aesthetic results. The obtainment of passive fits superior to those afforded by the traditional method confers increased stability at the prosthesis-implant interface, caring for and maintaining the soft and hard tissues over the long term.

Greater passive fit

The Phibo® CAD-CAM personalised prostheses system offers improved passive fit of the prosthesis, providing the clinician and laboratory with reliable and predictable long-term results.





Zirconium



Titanium



Cobalt Chrome



Science and technology to obtain predictable results

We are dedicated to science and technology

Phibo® conducts studies in bioengineering, biocompatibility, experimental techniques and computer simulation on its products.

Our working philosophy is supported by our knowledge and is warranted by scientific studies. We contribute to improved patient quality of life, thanks to better oral health, greater comfort and aesthetics. Phibo® continues to view comprehensive scientific research as the main reference of its values.

Phibo® is carrying out a variety of multicentric clinical studies, continuing the success of its products in cooperation with the most reputable universities and national and international centres of reference.

Fatigue studies

To guarantee the reliability of the Phibo® products, we conduct fatigue studies according to the international ISO 14801 norm, with the following results:

With cyclic loading at a frequency of 15 Hz, applied to the global implant and abutment at an angle of 30° from its axis, we exceed 5 million cycles with forces in excess of 350 N.

Phibo®, through its R&D+i activities, guarantees that the TSH® implant design offers optimum mechanical and biological behaviour. The reports of reputed technological centres such as Applus or Inasmet, among others, certify this behaviour.

Studies of finite elements

The F.E.M. consists of rendering complex geometries discrete in smaller portions (finite elements), which can be studied by traditional solid mechanics. Mathematical relations of balance are established between these elements, from which a general result is obtained regarding the stresses and deformities of the studied structure.

Based on the computer simulations, the conclusions drawn are the following:

Mechanics: *the geometric and balanced three-dimensional spatial design of its four connections allows stress distribution over the largest amount of surface - thus reducing the localised mechanical stress peaks.*

This prolongs material fatigue service life and approaches the requirements, objectives and functions of an ideal dental implant in the fixation and support of dental pieces.

Biomechanics: *the optimised design of the connections and their conical macrogeometrical characteristics ensure harmonic and coherent interaction of the implant with the biological supporting medium. The localised accumulation of stresses generated by the loads and chewing forces is avoided - thus allowing gradual energy release and force transmission to the bone-implant interface.*



Mechanical testing of fatigue life. Test machine (high frequency).

Selection of scientific references:

1. Buser, D. et al. Interface shear strength of titanium implants with a sandblasted and acid-etched surface: a biomechanical study in the maxilla of miniature pigs.
J Biomed Mater Res 45, 75-83 (1999).
2. Chee, W. et al. JOMI Current Issues Forum: Cemented vs. Screw-retained implant prostheses: Which is better?
Int J Oral Maxillofac Implants 14, 137-141 (1999).
3. Hansson, S., & Norton, M. The relation between surface roughness and interfacial shear strength for bone-anchored implants. A mathematical model.
J Biomech 32, 829-836 (1999).
4. Martínez-González, J.M., Cano, J., Campo, J., Martínez, J.M.S., and García, F.J. Diseño de los implantes dentales: estado actual.
Avances en Perodoncia 14, 129-136 (2002).
5. Masuda, T., Yliheikkilä, P.K., Felton, D.A. & Cooper, L.F. Generalizations regarding the process and phenomenon of osseointegration. Part I. In vivo studies.
Int J Oral Maxillofac Implants 13, 17-29 (1998).
6. Misch, C.E., Bidez, M.W. & Sharawy, M. A bioengineered implant for a predetermined bone cellular response to loading forces. A literature review and case report.
J Periodontol 72, 1276-1286 (2001).
7. Nishiguchi, S. et al. The effect of heat treatment on bone-bonding ability of alkali-treated titanium.
Biomaterials 20, 491-500 (1999).
8. Polmear IJ, (1981). "Light alloys. Metallurgy of the light metals". Metallurgy and materials Science Series.
Arnold. London. Pp. 239-278.
9. Semlitsch MF, Panic B, Weber H and Schoen R.(1981). "Comparison of the fatigue strength of femoral prosthesis stems made of forged Ti-Al-V and Cobalt base alloys".
In titanium Alloys in Surgical Implants. Luckey and Kubli Eds.
ASTM STP 796. Philadelphia pp.120-135.
10. Simmons,C.A., Meguid,S.A. & Pilliar,R.M. Differences in osseointegration rate due to implant surface geometry can be explained by local tissue strains.
Journal of Orthopaedic Research 19, 187-194 (2001).
11. Wong,M., Eulenberger,J., Schenk,R. & Hunziker,E. Effect of surface topology on the osseointegration of implant materials in trabecular bone.
J Biomed Mater Res 29, 1567-1575 (1995).
12. Zienkiewicz,O.C., El Método de los elementos finitos (4ª ed).
McGraw-Hill, ISBN 84-481-0178-2.

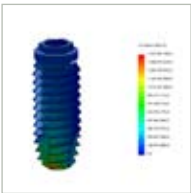

Finite element simulation techniques.



Test machine (high frequency).

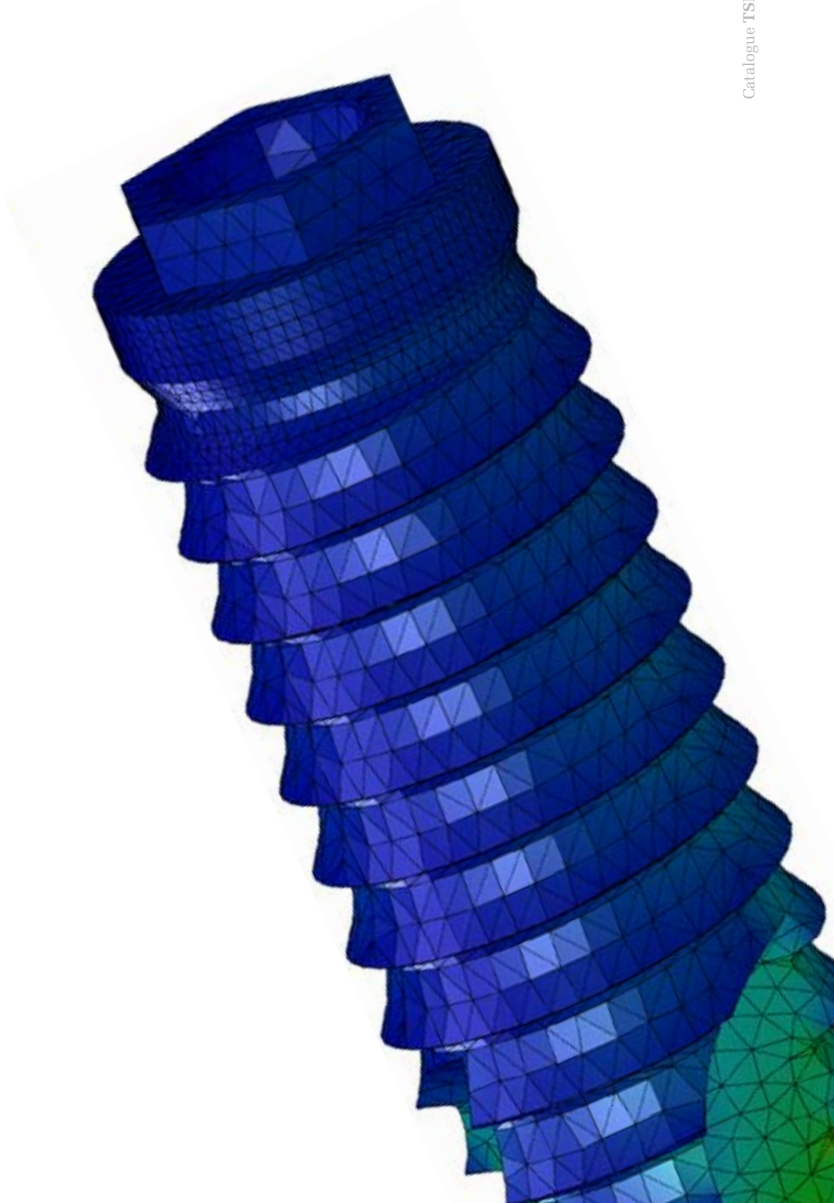

General characteristics

Insertion height

The TSH® implant is designed to position the implant platform above the bone crest. The drilling length for implant insertion is the length of the implant.

All TSH® implants are made of grade II titanium from titanium bars obtained by Cold-work according to the ASTM-F67 norm.



TSH® S2

Reference	Length
TSH 02.100	10.0 mm
TSH 02.115	11.5 mm
TSH 02.130	13.0 mm
TSH 02.145	14.5 mm
TSH 02.160	16.0 mm

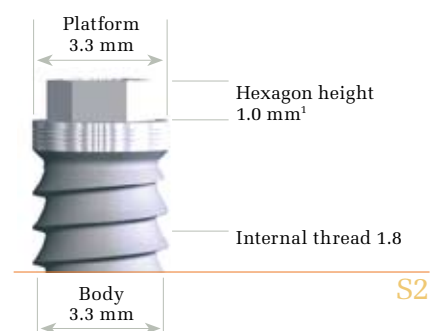

Cover screw¹



Healing abutment²

Reference	Height
H10.2030	3.0 mm
H10.2050	5.0 mm
H10.2070	7.0 mm

¹ Locking screw included. Colour anodised according to series.

² The healing abutments have no colour code. Titanium.

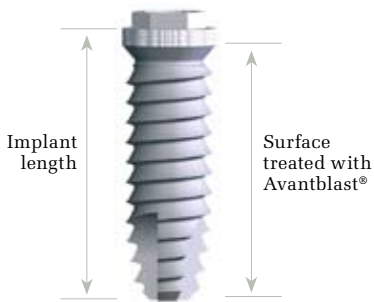

TSH® S3

Reference	Length
TSH 03.085	8.5 mm
TSH 03.100	10.0 mm
TSH 03.115	11.5 mm
TSH 03.130	13.0 mm
TSH 03.145	14.5 mm
TSH 03.160	16.0 mm

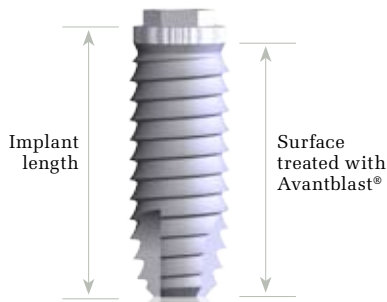

TSH® S4

Reference	Length
TSH 04.085	8.5 mm
TSH 04.100	10.0 mm
TSH 04.115	11.5 mm
TSH 04.130	13.0 mm
TSH 04.145	14.5 mm
TSH 04.160	16.0 mm

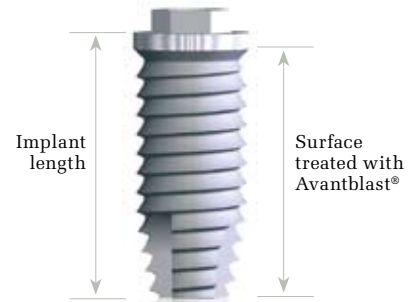

TSH® S5

Reference	Length
TSH 05.085	8.5 mm
TSH 05.100	10.0 mm
TSH 05.115	11.5 mm
TSH 05.130	13.0 mm

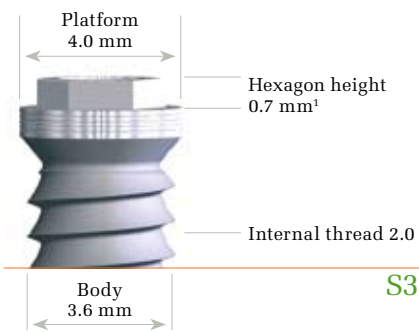

S3

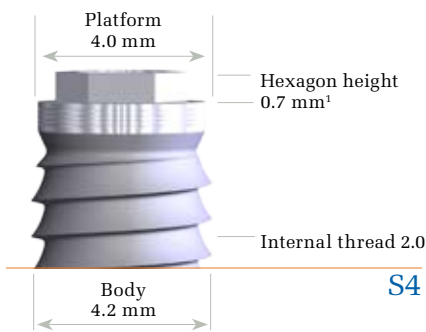

S4

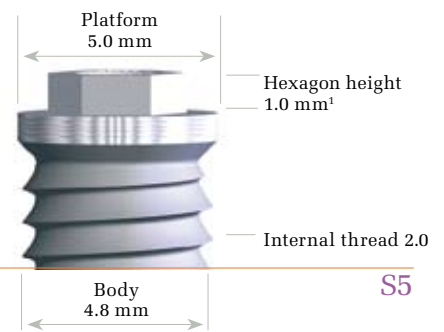

S5



Cover screw¹



Cover screw¹



Cover screw¹

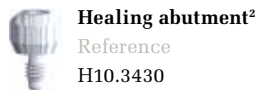

Healing abutment²

Reference	Height
H10.3430	3.0 mm
H10.3450	5.0 mm
H10.3470	7.0 mm

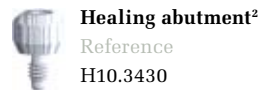

Healing abutment²

Reference	Height
H10.3430	3.0 mm
H10.3450	5.0 mm
H10.3470	7.0 mm

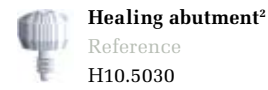

Healing abutment²

Reference	Height
H10.5030	3.0 mm
H10.5050	5.0 mm

Restorations

SINGLE

SCREWED

CEMENTED



MULTIPLE

SCREWED

CEMENTED



OVERDENTURES



Retained bar



Non-hexed casting cylinder



Hexed casting cylinder



Phibo® CAD-CAM
Zirconium, Titanium and Cobalt Chrome



Drillable abutment



Angled abutment



Phibo® CAD-CAM
Zirconium, Titanium and Cobalt Chrome



Non-hexed casting cylinder



Phibo® CAD-CAM
Zirconium, Titanium and Cobalt Chrome



Drillable abutment



Angled abutment



Phibo® CAD-CAM
Zirconium, Titanium and Cobalt Chrome

Locator®



Locator®

Retained ball







Ball abutment

Phibo® CAD-CAM





Titanium and Cobalt Chrome



Screwed restorations

	Series	Reference	Dimensions	Designation
	S2	H38.2001		Hexed casting cylinder. <i>Plastic.</i>
	S3 S4	H38.3401		
	S5	H38.5001		
	S2	H38.2002		Non-hexed casting cylinder. <i>Plastic.</i>
	S3 S4	H38.3402		
	S5	H38.5002		
	S2	H18.2000	M1.8	Laboratory screw. <i>Titanium.</i>
	S3 S4 S5	H18.3450	M2.0	
	S2	H19.2000	M1.8	Final clinical screw. <i>Titanium.</i>
	S3 S4 S5	H19.3450	M2.0	

Cemented restorations

	Series	Reference	Designation
	S2	H20.2020	Hexed post abutment with shoulder 2.0mm <i>Titanium.</i>
	S3 S4	H20.3420	
	S5	H20.5020	
	S2	H20.2040	Hexed post abutment with shoulder 4.0mm <i>Titanium.</i>
	S3 S4	H20.3440	
	S5	H20.5040	
	S3 S4	H23.3415	Angled Abutment 15°. Shoulder 0.5 mm. Hexed with screw. Dimensions: M2.0 <i>Titanium.</i>
	S3 S4	H23.3425	Angled Abutment 25°. Shoulder 0.5 mm. Hexed with screw. Dimensions: M2.0 <i>Titanium.</i>
	S3 S4	H22.3415	Angled Abutment 15°. Shoulder 1.5 mm. <i>Titanium.</i>
	S3 S4	H22.3425	Angled Abutment 25°. Shoulder 1.5 mm. <i>Titanium.</i>

Overdenture restorations

	Series	Reference	Designation
	S3 S4	H22.3402*	Ball abutment. <i>Titanium.</i> Height: 2.0 mm.
	S3 S4	H22.3404*	Height: 4.0 mm.
	S3 S4	022.0010	Ball abutment metal sleeve. <i>Titanium.</i>
	S3 S4	022.0005	Ball abutment seal. <i>EPDM.</i>

*Important: Not indicated for restorations with disparallelisms of over 30° between implants.

Overdenture restorations

Locator®



	Series	Reference	Designation
	S2	1916	Locator® abutment. Height: 1 mm. <i>Titanium</i>
	S3 S4	1942	
	S2	1917	Height: 2 mm. .
	S3 S4	1943	
	S5	1922	
	S2	1918	Height: 3 mm.
	S3 S4	1944	
	S5	1923	
	S2	1919	Height: 4 mm.
	S3 S4	1945	
	S2	1920	Height: 5 mm.
		8519	Retention kit (2 units).
		8540	Extended retention kit (2 units).
		8514	Block out spacer (20 units.)
		8393	Locator® tool.
		8530	Analog (4 units).
		8505	Impression coping (4 units).
		8517	Parallel post (4 units).
		9530	Angulation guide.

Locator® is a registered trademark of Zest Anchors, Inc.

Imprinting

	Series	Reference	Dimensions	Designation
	S2	H11.2000	M1.8	Imprint transfer.
	S3 S4	H11.3400	M2.0	Short screw: closed tray.
	S5	H11.5000	M2.0	Long screw: open tray. <i>Titanium.</i>
	S2	H12.2000	M1.8	Implant analog.
	S3 S4	H12.3400	M2.0	<i>Titanium.</i>
	S5	H12.5000	M2.0	

Planning instruments

	Reference	Designation
	170.0002	Radiographic template: 1:1 / 1.25:1 / 1.3:1 <i>Plastic.</i>
	170.2000	Open Guide® (4 units). <i>Titanium.</i>

Surgical box





Reference	Designation
171.0300	Surgical Box





Surgical instruments and prosthodontics

Surgical instruments TSH®



	Series	Reference	Designation
	S2	151.0002	Circular scalpel. TSH. <i>Stainless.</i>
	S3	151.0003	
	S4	151.0004	
	S5	151.0005	

		173.0000	Drill Extender.
---	--	----------	-----------------



Mechanical insertion TSH®

	Reference	Designation
	173.0100	Contra-Angle Adapter, Short. Connection: mounter. <i>Stainless.</i>
	173.0300	Contra-Angle Adapter, Long. Connection: mounter. <i>Stainless.</i>
	173.1251	Contra-Angle Hex Driver, Short. Connection: 1.25 mm. <i>Stainless.</i>
	173.1252	Contra-Angle Hex Driver, Medium. Connection: 1.25 mm. <i>Stainless.</i>

Manual insertion TSH®







	Reference	Designation
	172.0000	Torque wrench. <i>Stainless.</i>
	172.0001	Open end wrench. <i>Titanium.</i>
	172.0100	Ratchet Adapter, Short - to Mounter. Connection: mounter. <i>Titanium.</i>
	172.0300	Ratchet Adapter, Long - to Mounter. Connection: mounter. <i>Titanium.</i>

Surgical instruments and prosthodontics 1.25

	Reference	Designation
	174.1251	Manual Hex Driver, Short. Connection: 1.25 mm. <i>Stainless.</i>
	174.1252	Manual Hex Driver, Medium. Connection: 1.25 mm. <i>Stainless.</i>
	174.1253	Manual Hex Driver, Long. Connection: 1.25 mm. <i>Stainless.</i>
	172.1251	Hex Tool, Short - to Wrench. Connection: 1.25 mm. <i>Stainless.</i>
	172.1252	Hex Tool, Medium - to Wrench. Connection: 1.25 mm. <i>Stainless.</i>

Surgical instruments: initial sequence

Initial sequence TSH®

	Reference	Designation
	175.0001	Precision Drill. <i>Stainless.</i>
	175.1018	Round Marking Bur. Dimensions: \varnothing 1.8 mm. <i>Stainless.</i>
	175.1023	Dimensions: \varnothing 2.3 mm.
	176.1323	Pilot Drill, Long. Dimensions: \varnothing 2.3 mm. <i>Stainless.</i>
	176.1123	Pilot Drill, Short.
	177.0000	Pilot Drill Parallelizer. Dimensions: \varnothing 2.3 mm. <i>Titanium.</i>

Crestal Insertion



The TSH® implant is designed to position the implant platform above the bone crest. The drilling length for implant insertion is the length of the implant.

Further information on the surgical procedure is available at: www.phibo.com

SEQUENCE:

The planned depth and direction of implant insertion is established in the initial surgical drilling sequence.

Once initial drilling has been completed, we continue with the next sequences until final drilling corresponding to the planned implant diameter and series - leaving the bone bed prepared for implant insertion.

IMPORTANT:

Insertion instruments with laser marking of depth.

The surgical drills are indicated for a maximum of 10 uses. Exceeding the indicated number of uses can adversely affect the success of implant treatment.





Surgical instruments: final sequence

Final sequence TSH® S2

	Reference	Designation
	178.1328	Surgical Drill, Long. <i>Dimensions: ø 2.8 mm. Stainless.</i>
	178.1128	Surgical Drill, Short. <i>Dimensions: ø 2.8 mm. Stainless.</i>
	179.0028	Depth Indicator Drill. <i>Dimensions: ø 2.8 mm. Titanium.</i>
	181.0333*	Contra-Angle Bone Tap, Long. Manual via Ratchet Adapter, Long ref. 172.0300. <i>Dimensions: ø 3.3 mm. Stainless.</i>
	181.0133*	Contra-Angle Bone Tap, Short Manual via Ratchet Adapter, Long ref. 172.0300. <i>Dimensions: ø 3.3 mm. Stainless.</i>

* Use in bone with type I-II bone quality.





Final sequence TSH® S3

	Reference	Designation
	178.1330	Surgical Drill, Long. <i>Dimensions: ø 3.0 mm. Stainless.</i>
	178.1130	Surgical Drill, Short. <i>Dimensions: ø 3.0 mm. Stainless.</i>
	179.0030	Depth Indicator Drill. <i>Dimensions: ø 3.0 mm. Titanium.</i>
	181.0336*	Contra-Angle Bone Tap, Long. Manual via Ratchet Adapter, Long ref. 172.0300. <i>Dimensions: ø 3.6 mm. Stainless.</i>
	181.0136*	Contra-Angle Bone Tap, Short Manual via Ratchet Adapter, Long ref. 172.0300. <i>Dimensions: ø 3.6 mm. Stainless.</i>

* Use in bone with type I-II bone quality.



Surgical instruments: final sequence

Final sequence TSH® S4

	Reference	Designation
	178.1336	Surgical Drill, Long. <i>Dimensions: ø 3.6 mm. Stainless.</i>
	178.1136	Surgical Drill, Short.
	179.0036	Depth Indicator Drill. <i>Dimensions: ø 3.6 mm. Titanium.</i>
	181.0342*	Contra-Angle Bone Tap, Long. Manual via Ratchet Adapter, Long ref. 172.0300.
	181.0142*	<i>Dimensions: ø 4.2 mm. Stainless.</i> Contra-Angle Bone Tap, Short. Manual via Ratchet Adapter, Long ref. 172.0300.

* Use in bone with type I-II bone quality.

Final sequence TSH® S5

	Reference	Designation
	178.1241	Surgical Drill, Short. <i>Dimensions: ø 4.1 mm. Stainless.</i>
	179.0041	Depth Indicator Drill. <i>Dimensions: ø 4.1 mm. Titanium.</i>
	181.0248*	Contra-Angle Bone Tap. Manual via Ratchet Adapter, Long ref. 172.0300. <i>Dimensions: ø 4.8 mm. Stainless.</i>

* Use in bone with type I-II bone quality.

Sales conditions

1. GENERAL SERVICE - We adapt to you.

Client Service telephone 937 151 978 | Hours: Monday to Friday 9:00 a.m. to 1:30 p.m. and from 3:00 p.m. to 6:00 p.m. (except holidays).

2. PRODUCT ORDERING - For your convenience, we have extended our office hours.

Monday to Friday 9:00 a.m. to 1:30 p.m. and from 3:00 p.m. to 6:00 p.m. (except holidays) | Client Service telephone 937 151 978.

3. SUPPLY DEADLINES - We maintain the stock for you.

- 24-48 h. Spanish peninsula (*) Deadlines according to reception of orders and office hours, as specified in section 2.
- 48-72 h. Insular (*) Deadlines according to reception of orders and office hours, as specified in section 2.

(*) Exclusive for the current products of the Phibo® implant system (except holidays).

4. SHIPPING OF PRODUCTS - For when you need them.

Upon placing your order, tell us the type of service you require.

- a) Delivery from 8:00 a.m. to 10:00 p.m. Monday to Friday.
- b) Delivery after 10:00 a.m. (*), according to shipping deadlines as specified in section 3. Monday to Friday.

(*) We cover the shipping and processing costs in section "b)" in the case of those material orders that equal or exceed 300 €, taxes not included.

5. PRODUCT RETURNS

Given the benefits derived from our products and sales conditions, returns will only be accepted of material pertaining to the Phibo® system in the 30 days following the invoice date, and provided the following conditions are met:

- a) Before shipping the material, request the product return number from our Client Service, Tel. 937 151 978, and identify the material along with the article code, amount and batch number.
- b) All documents accompanying the merchandise, as well as the outer packaging, must state the number supplied by our Client Service.
- c) Material not in perfect condition will not be accepted: there must be no opening, manipulation, marking or relabeling.
- d) Having assigned the return number and received the material in our facilities, and following the pertinent quality controls, we will issue the corresponding credit, to be compensated by future purchases.
- e) The shipping costs associated with product return will be covered by the client.
- f) Material from a commercial promotion invoiced by Phibo® will not be admitted.

6. REPLACEMENT OF IMPLANTS AND PROSTHESES

Replacements of Phibo® products will be accepted during a maximum period of 12 months after the invoice date, provided the following conditions are met:

- a) Before shipping the material, request the product replacement number from our Client Service, and identify the material along with the article code, amount and batch number.
- b) Material not in perfect condition will not be accepted: there must be no damage, manipulation, marking or relabelling.
- c) Material with an expiration date of less than 6 months will not be accepted.
- d) The material is to be shipped in protective packaging in order to avoid damage during shipment.
- e) The costs of both reception and shipment, associated with product replacement, will be covered by the client.
- f) No material will be accepted for change unless it complies with the preceding conditions.

7. INVOICING AND PAYMENT - Simple, Automatised

Delivery notes and invoices will be automatically attached to the ordered product. The standard payment procedure is by bank account 30 days after the invoice date.

8. WE ARE INTERESTED IN YOUR OPINION

Phibo® offers its clients an effective tool for contributing to the continued improvement of our services and products. If you inform us of any incidents or comments, we can be much more effective. Our Client Service will enter your comments and observations in a special client fidelisation program. We automatically activate a series of in-house processes to evaluate or reply to your comments. Your suggestions and evaluations will be greatly appreciated.

Feedback is generated thanks to your cooperation, and allows us to take the opportune actions to ensure continuous improvement of our services: for your full satisfaction.

· Taxes not included.

· Phibo® and other brands of this catalogue are registered trademarks of Phibo Dental Solutions, S.L.

· Phibo Dental Solutions, S.L. reserves the right to modify the prices or products, or to correct mentions resulting from typographical errors, without prior warning.

This document was reviewed and approved on: 2011-03-04.



TSH®

Phibo® Headquarters

P. I. Mas d'en Cisa
Gato Pérez, 3-9
08181 Sentmenat
Barcelona | Spain
T +34 937 151 978
F +34 937 153 997

www.phibo.com

REF: CATTSHEN_rev003

